

**TEMPERATURE
RESISTANCE PROBE
TYPE:**

KH

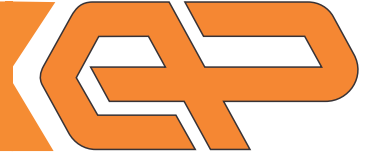

Description of the probe:

Temperature resistance probe type KH is used for measuring the air temperature up to 100°C in ventilation channels or chambers. The probe is attached to the channel's or chamber's wall with the PE 12 fastener.

Sensor features:

Sensors, which can be implemented into the measuring insert of the probe:

- Pt 100
 - tolerance class A*
 - tolerance class B*
 - two-wire implementation
 - three-wire implementation
 - four-wire implementation
- Pt1000
 - tolerance class B*
 - two-wire implementation
- NTC 10K
- KTY 81
- Ni1000, 5000 ppm/K
- Ni1000, 6178 ppm/K

(refer to the ordering table)

* according to DIN EN 60751

External features of the probe:

Measuring insert tube is made out of ANSI 403 (DIN 1.4024) steel. Process connector measures 1/2".

Mounting length of the probe (Lv) can be:

- 100 mm
- 200 mm
- 300 mm
- 400 mm
- 500 mm

(refer to the ordering table)

Image and dimensions of the probe:

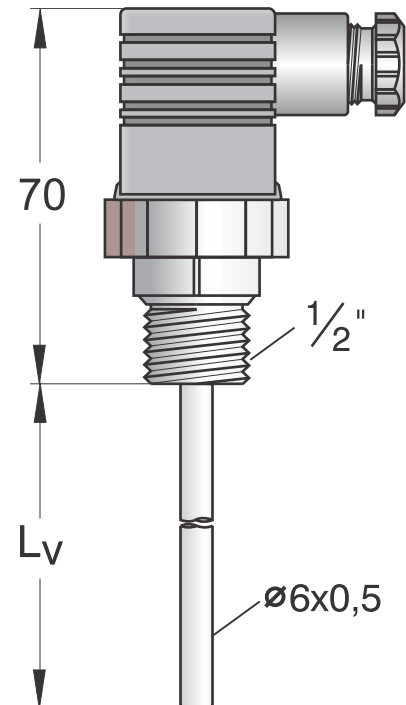

Operating conditions and maintenance:

Temperature

Temperature interval for KH is -40/100°C.

Reaction time

$T_{0.5} < 20s.$

Pressure

Maximum pressure of the medium is 10 bar.

Maintenance

The probe does not need any maintenance.

Plug-in connector:

Plastic plug-in connector with terminals according to standard DIN EN 175 301-803-A and cable gland PG9.

Protection level IP65.

